

**1. Handling**

**Unit Volume / Weight**

Unit Ref : **LG4-FS**  
 Volume : **0.477 m³**  
 Weight : **1125 kg**

Weight is based on 2,350 kg/m³

Primary lifting is by the associated fork slot or by means of a 180mm long spherical pin anchor rated at 5.0 tonnes with a safety factor of 3.

All lifting methods should comply with the Lifting Operation & Lifting Equipment Regulations 1998 (LOLER).

**Lifting Pin Characteristics**

Anchor Type : **T-050-0180**  
 Anchor Length : **180mm**  
 dia : **20mm**  
 Foot dia : **50mm**  
 Load Class : **5.0 tonnes**

**IMPORTANT NOTE :**

Prior to lifting older / pre-used blocks, check the lifting pin for wear / corrosion and check the block for cracks. If the block is cracked or the pin is worn, it could fail when lifting.

**2. Concrete**

Characteristic 28 day cube strength = 50 N/mm² min.  
 Concrete is Class A1 Fire Resistant in accordance with clause 4.3.4.4 of EN 13369

**3. Manufacture**

Manufactured to : **BS EN 13369 : 2013**  
 Tolerances to : **BS EN 13670 : 2009**

**4. Physical & Chemical Properties**

Appearance : Grey in Colour  
 Other Chemical Properties : Not Applicable

**5. Design**

Design Life : **>100 years**

**6. Manufacture Tolerances**

Length **±5mm**  
 Width **±5mm**  
 Height **±5mm**

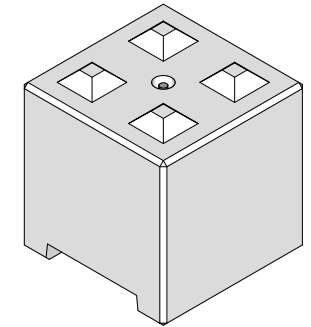
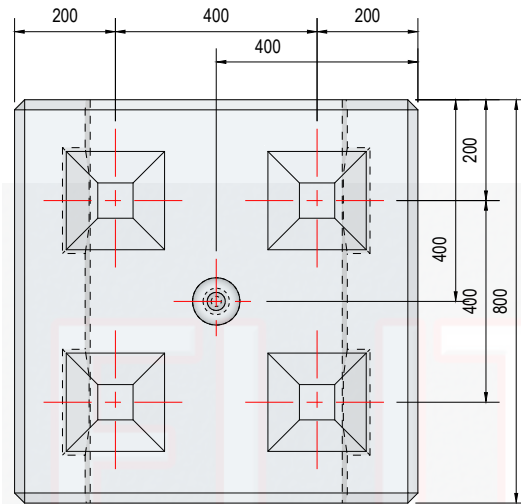

**2. Concrete**

Characteristic 28 day cube strength = 50 N/mm² min.  
 Concrete is Class A1 Fire Resistant in accordance with clause 4.3.4.4 of EN 13369

**3. Manufacture**

Manufactured to : **BS EN 13369 : 2013**  
 Tolerances to : **BS EN 13670 : 2009**

**4. Physical & Chemical Properties**

Appearance : Grey in Colour  
 Other Chemical Properties : Not Applicable

**5. Design**

Design Life : **>100 years**

**6. Manufacture Tolerances**

Length **±5mm**  
 Width **±5mm**  
 Height **±5mm**

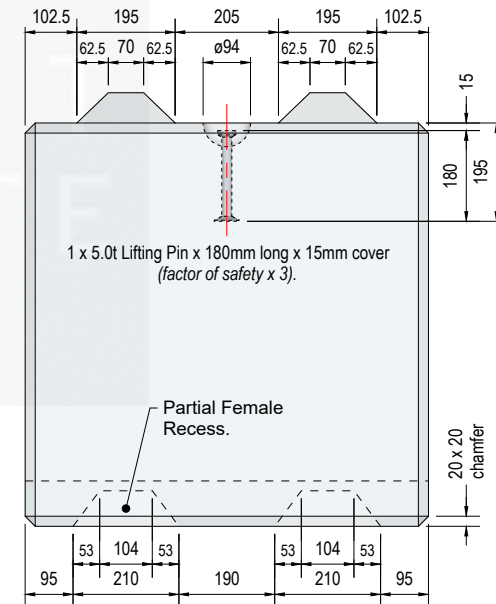
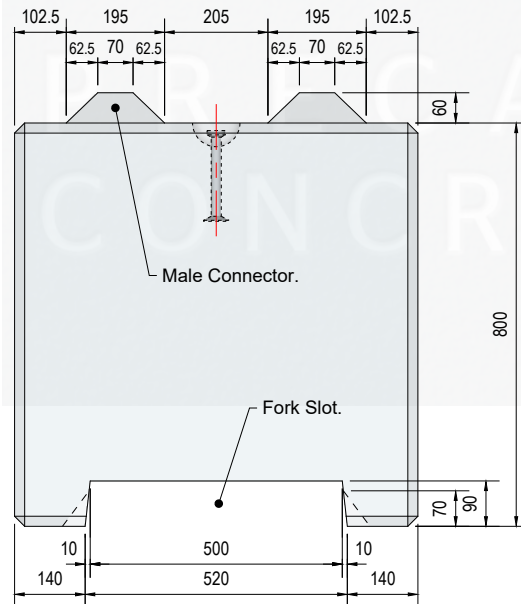

REV	DATE	REASON FOR ISSUE	DRN	APP
A	24.10.24	Title block updated.	CTC	RMD
O	24.05.23	First Issue.	CTC	RMD

TITLE				
Legato® Marquee Block with Fork Slot 800mm x 800mm x 800mm x 1125kg Elite Product Code : <b>LG4-FS</b>				
DRN	CTC	CHKD	RMD	DATE
				24-05-23

ELITE PRECAST CONCRETE LTD HALESFIELD 9, TELFORD SHROPSHIRE TF7 4QW www.eiiteprecast.co.uk			SIZE	SCALE	DRG	REV
			A4	1:15	EPC-LG4-FS	A