

Kentledge Blocks

Precast concrete kentledge blocks are used to act as ballast or counterweights for fencing, hoarding, scaffolding, or for various temporary works. By using precast concrete kentledge blocks for above ground/no-dig fencing and hoarding systems you avoid the risk of costly service strikes. They can also be attached to wire ropes which are fixed to the structure to provide greater stability.

The Elite Kentledge block range also have huge advantages over other counterweight solutions in that they are 100% recyclable (i.e. they are cast from simple and pure Portland Cement and Quarried, locally sourced aggregates), reusable (the blocks have many other uses) and resalable (the vast majority of Elite's Kentledge blocks supplied to major projects are eventually re-sold to create material storage bays after their primary job is completed).

Elite's huge variety of 50N/mm² blocks means that whatever the application we will have a block or combination of blocks that will meet your requirements.

Our blocks are used extensively by maritime fabrication businesses for use in the off-shore wind turbine sector, as counterweights for dock-side cranes (for example as strand jack guy rope anchors) and are used extensively in dry docks for ship supports.

Supplier of precast concrete kentledge blocks to the London 2012 Games (Olympic venues)

Traveling quickly and or traveling over rough terrain when carrying blocks or barriers should be avoided as excessive sudden jerking movements could damage the pin anchor. Prior to lifting older/pre-used blocks check the lifting pin for wear/corrosion and check the block for cracks. If the block is cracked or the pin is worn it could fail when being lifted.

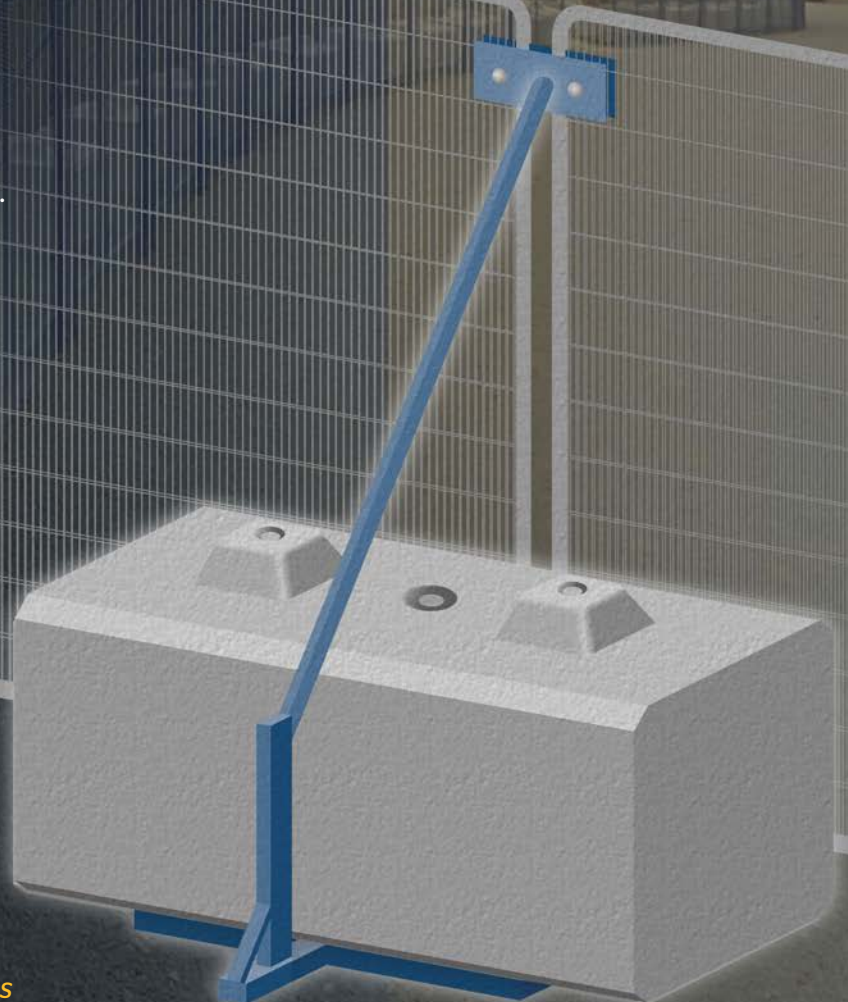

For more information on Elite quality concrete products
phone 01952 588 885 or browse www.eliteprecast.co.uk

Kentledge Blocks

Elite offer a choice of products which can be used as kentledge/ballast blocks. The blocks shown and highlighted in red opposite are our most popular.

Duo interlocking block

750kg

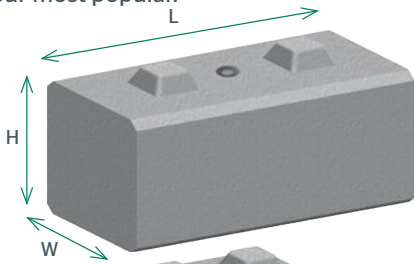

Legato interlocking block

1200kg

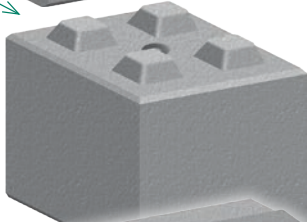

Hoarding blocks

1500kg
1233kg
970kg
700kg

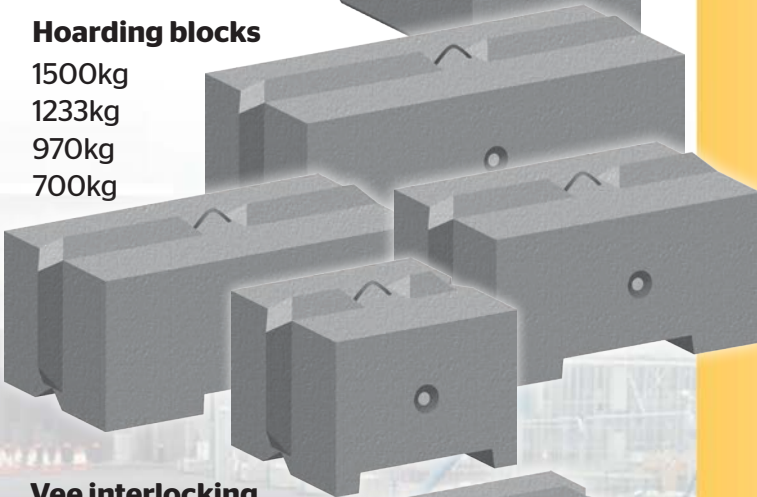

Vee interlocking blocks

1600kg

1333kg

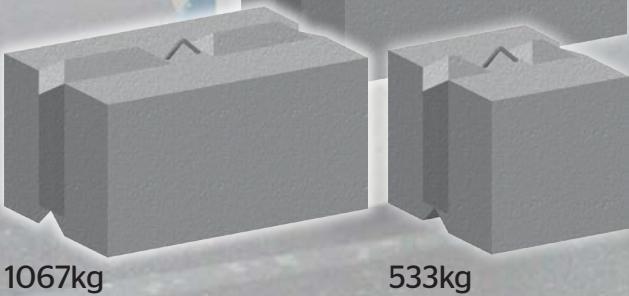

1067kg

533kg

Type	Code	Weight	Length	Width	Height
Marquee	KM1000	1100kg	1000mm	750mm	750mm
Marquee	KM500	480kg	1000mm	550mm	450mm
Hoarding	P1-1830	1500kg	1830mm	610mm	610mm
Hoarding	P1-1525	1233kg	1525mm	610mm	610mm
Hoarding	P1-1220	970kg	1220mm	610mm	610mm
Hoarding	P1-915	700kg	915mm	610mm	610mm
Legato	KL61200	1200kg	800mm	800mm	800mm
Duo	KL750	750kg	1200mm	600mm	450mm
Duo	KL375	375kg	600mm	600mm	450mm
Vee	KV1600	1600kg	1830mm	610mm	610mm
Vee	KV1333	1333kg	1525mm	610mm	610mm
Vee	KV1067	1067kg	1220mm	610mm	610mm
Vee	KV800	800kg	915mm	610mm	610mm
Vee	KV533	533kg	610mm	610mm	610mm
Scaffold	KS1150	1150kg	1000mm	1000mm	500mm
Solar	KZ1000	1000kg	2300mm	460mm	400mm
Cube	KC1000	1000kg	1000mm	1000mm	425mm
Duo	KC1125	1125kg	1800mm	600mm	450mm
Security	KS2000	2000kg	1220mm	990mm	750mm
Cube	KC2350	2350kg	1000mm	1000mm	1000mm
Cube	KC2950	2950kg	1000mm	1000mm	1250mm
MOD	KX3000	3000kg	1400mm	1400mm	700mm

Scaffold block

1150kg

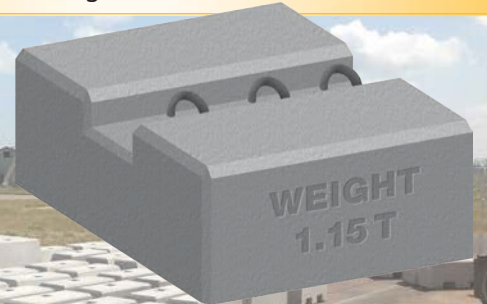

Marquee blocks

1100kg

480kg

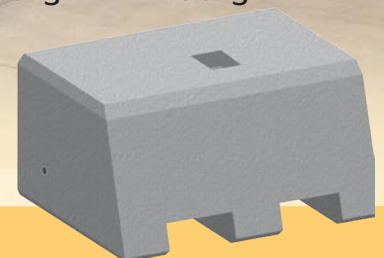
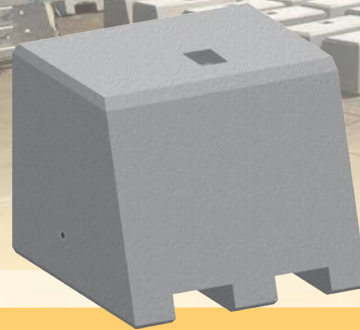

ELITE
PRECAST CONCRETE

Elite Precast Concrete Limited
Unit O, Halesfield 9
Telford, Shropshire TF7 4QW
Tel: 01952 588885
www.eliteprecast.co.uk

Important note: Prior to lifting older / pre-used blocks check the lifting pin for wear / corrosion and check the block for cracks. If the block is cracked or the pin is worn it could fail when being lifted.