

**1. Handling**

• Unit Volume / Weight

Unit Ref : LG2  
 Volume : 0.253 m³  
 Weight : 600 kg

• Weight is based on 2,350 kg/m³

• Lifting system is by means of a 180mm long spherical pin anchor rated at 2.5 tonnes with a safety factor of 3.

• Lifting is achieved by use of a 2.5t rated pin anchor ring clutch or combination ring clutch only and should comply with the Lifting Operation & Lifting Equipment Regulations 1998 (LOLER).

• Lifting Pin Characteristics

Anchor Type : T-050-0180  
 Anchor Length : 180mm  
 dia : 20mm  
 Foot dia : 50mm  
 Load Class : 5.0 tonnes

**IMPORTANT NOTE :**

Prior to lifting older / pre-used blocks, check the lifting pin for wear / corrosion and check the block for cracks. If the block is cracked or the pin is worn, it could fail when lifting.

**2. Concrete**

- Characteristic 28 day cube strength = 50 N/mm² min.
- Concrete is Class A1 Fire Resistant in accordance with clause 4.3.4.4 of EN 13369

**3. Manufacture**

- Manufactured to : BS EN 13369 : 2013
- Tolerances to : BS EN 13670 : 2009

**4. Physical & Chemical Properties**

- Appearance : Grey in Colour
- Other Chemical Properties : Not Applicable

**5. Design**

- Design Life : >100 years

**6. Manufacture Tolerances**

- Length ±5mm
- Width ±5mm
- Height ±5mm

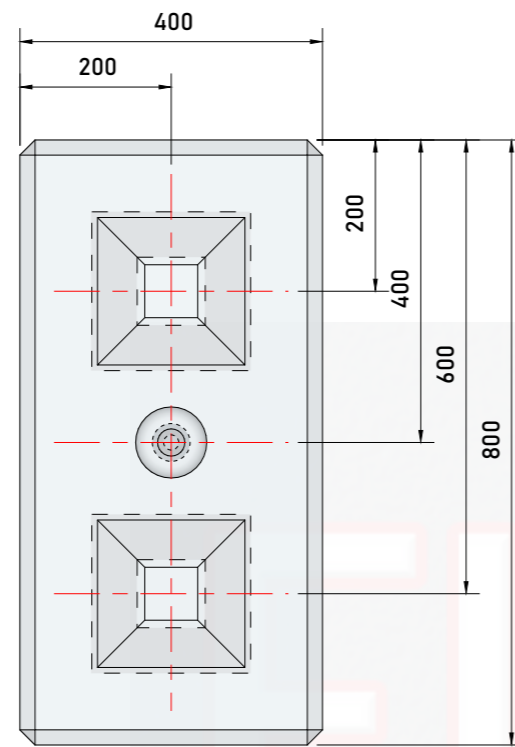

**TOP**

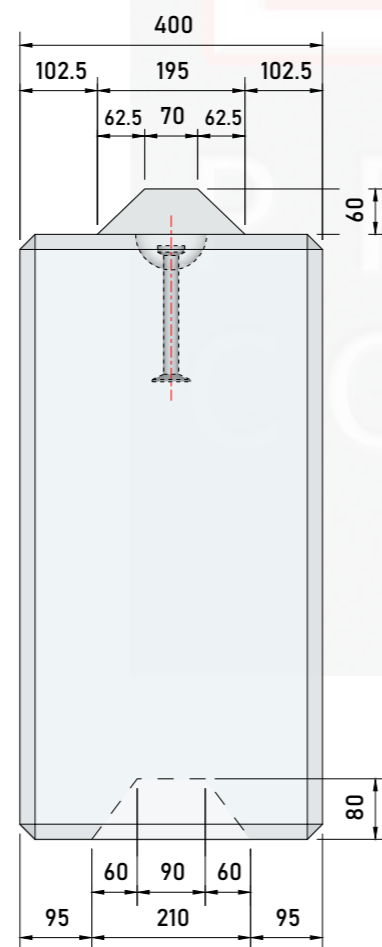

**FRONT**

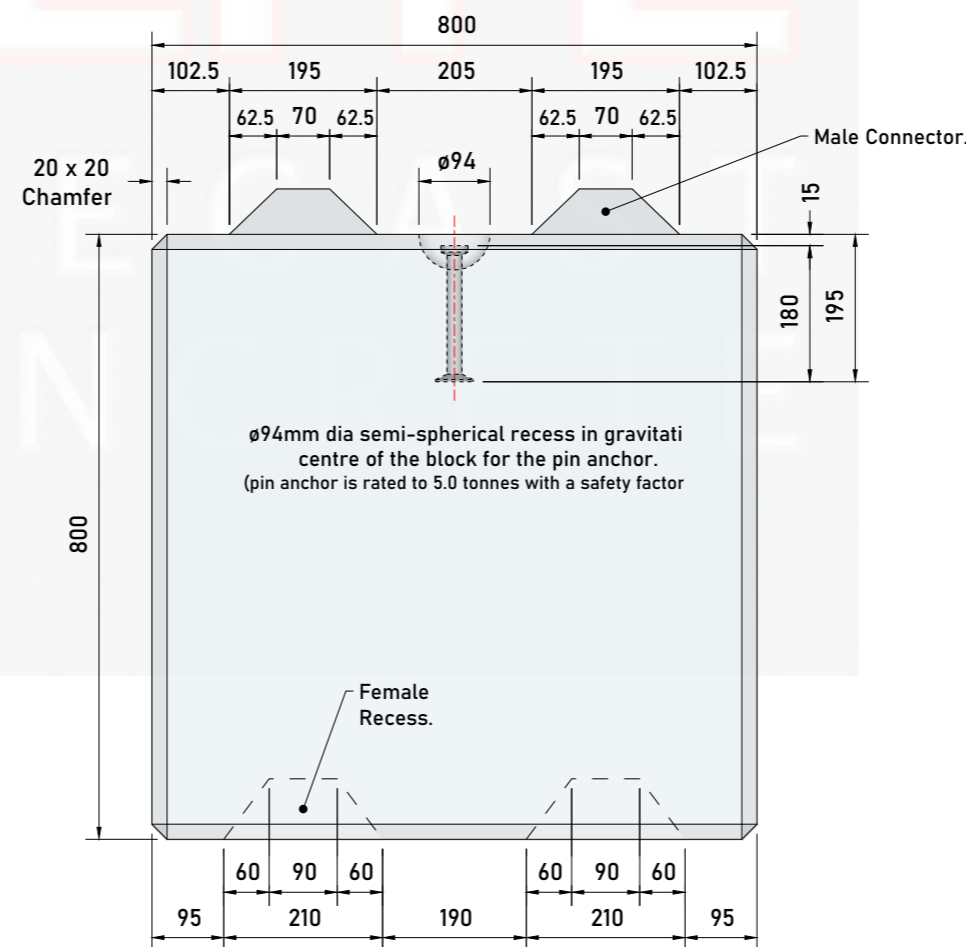

**SIDE**

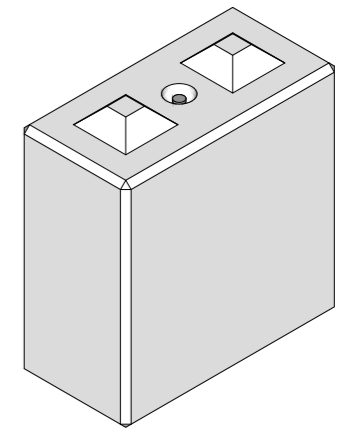

**Isometric View**

					C	20.01.22	Drawing & title block updated.	CTC	RMD	TITLE <b>Legato® Interlocking Concrete Block</b> 400mm x 800mm x 800mm (Male / Female Interlocks) Elite Product Code : LG2	ELITE PRECAST CONCRETE LTD HALESFIELD 9, TELFORD SHROPSHIRE TF7 4QW www.eliteprecast.co.uk	
				B	12.03.20	Registered Trademark ® added to the drawing.	CTC	RMD				
				A	03.01.18	Drawing revised & updated.	CTC	RMD				
				O	23.06.16	For information.	CTC	RMD				
D	20.01.23	Title block & notes updated.	CTC	RMD	O	23.06.16	For information.	CTC	RMD	DRN CTC CHKD RMD DATE 23-06-16	SIZE A3 SCALE 1:10 DRG EPC-LEG-002 REV D	
REV	DATE	REASON FOR ISSUE	DRN	APP	REV	DATE	REASON FOR ISSUE	DRN	APP			