

Notes

- Dimensions in millimetres
- Tolerance to be $\pm 0.5\%$ unless otherwise stated.
- For reinforcement details see drawing EPC-TVCB-008 & EPC-TVCB-009.
- Concrete mix C50 or C40 with air entrapment.
- The overlap of the scarf joint must always be in the direction of traffic.
- Manufacturer to establish weight from a sample unit, estimated weight of unit 1700Kg.

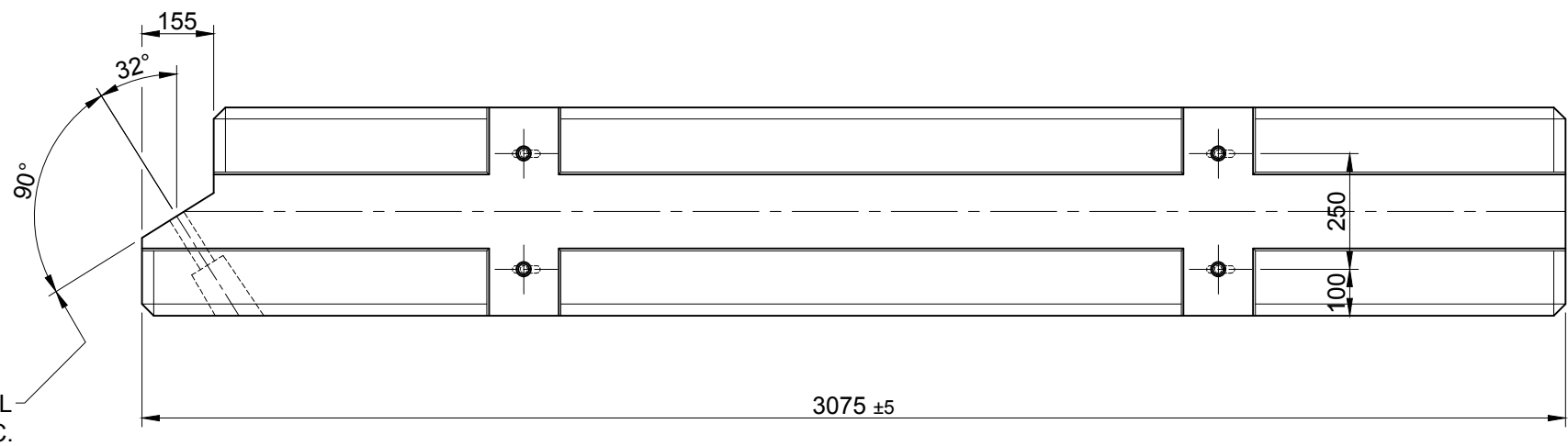
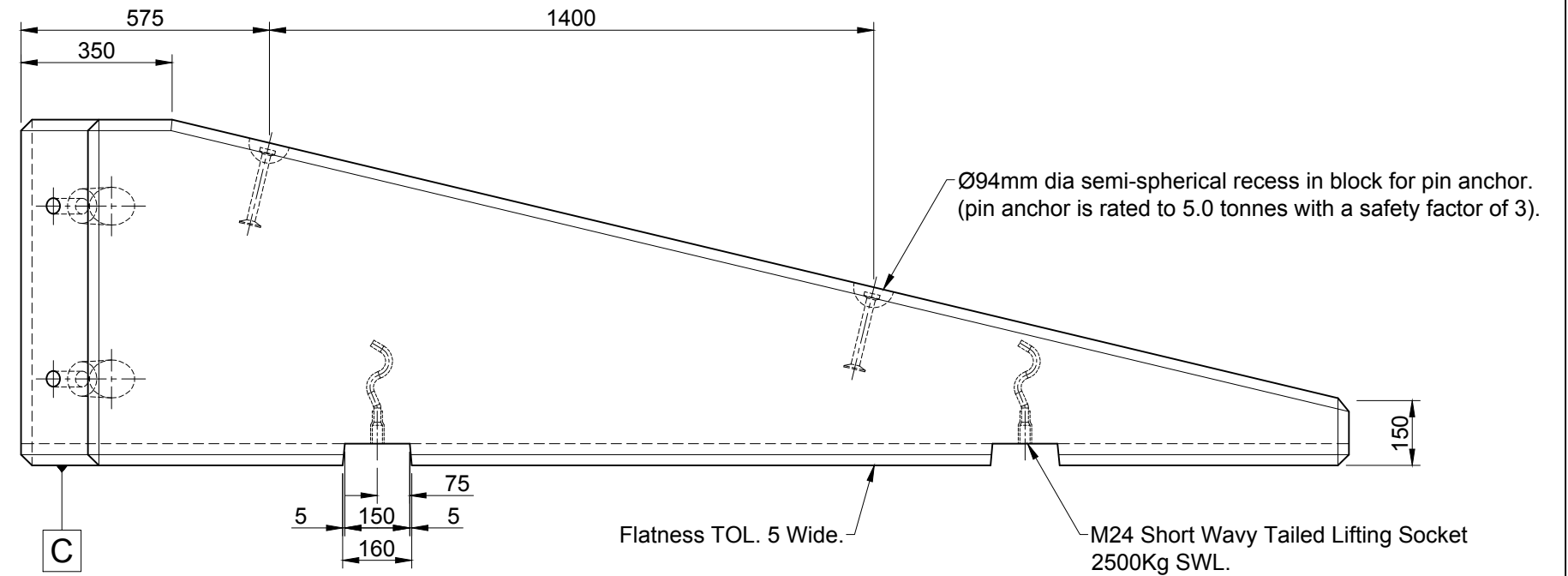
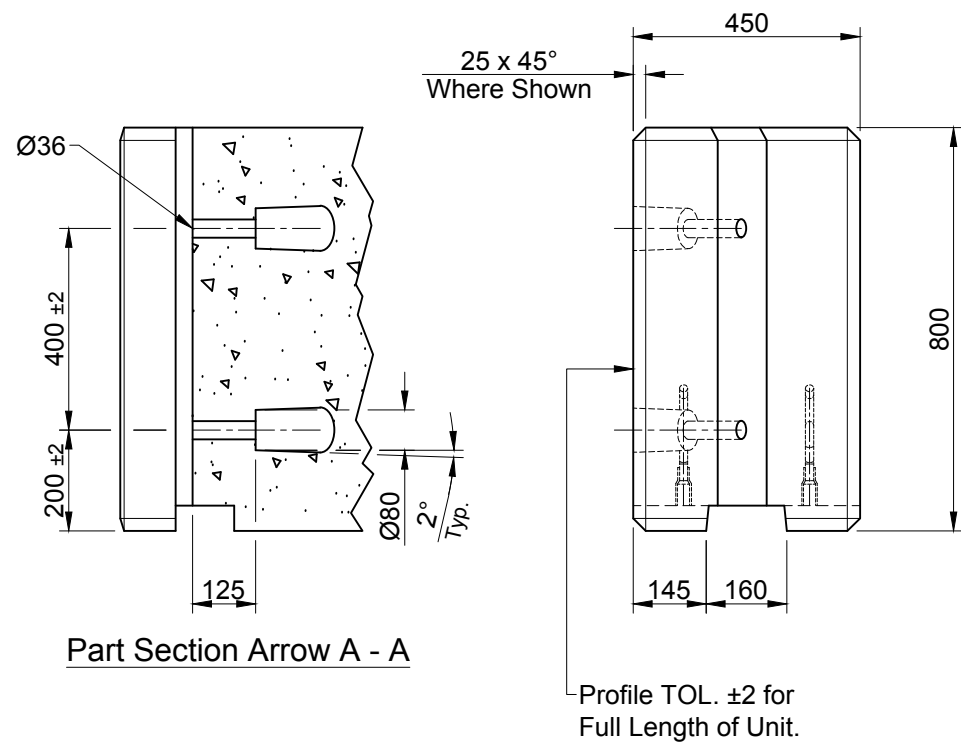
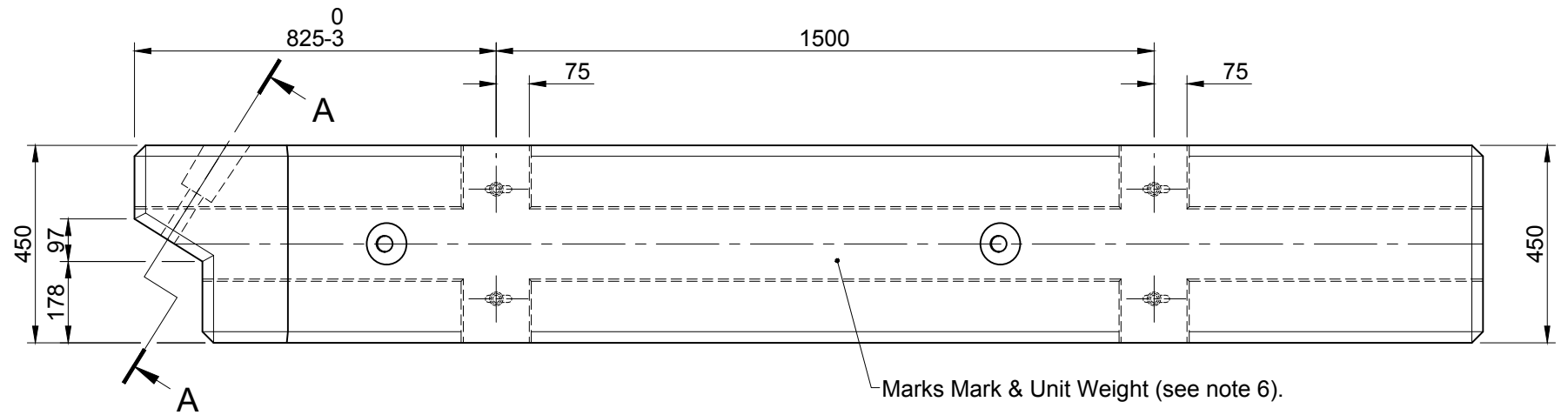

										TITLE Temporary Vertical Concrete Barrier (TVCB) Terminal Unit (Verge) Elite Product Code : V29			ELITE PRECAST CONCRETE LTD HALESFIELD 9, TELFORD SHROPSHIRE TF7 4QW												
										CTC	RMD														
										CTC	RMD														
REV	DATE	REASON FOR ISSUE	DRN	APP	REV	DATE	REASON FOR ISSUE	DRN	APP			DRN	CTC	CHKD	RMD	DATE	20-03-14	SIZE	A3	SCALE	1:15	DRG	EPC-TVCB-006	REV	A