

1. Handling

- Unit Weight

Unit Ref : **1197 Channel Lid**
 Weight : **220 kg**
 (including rebar)

- Weight is based on 2,350 kg/m³
- Lifting system is by means of 2 no. 55mm long spherical pin anchors rated at 2.5 tonnes with a safety factor of 3.
- Lifting is achieved by use of 2 no. 2.5t rated suitable pin anchor ring clutches or combination ring clutches only and should comply with the Lifting Operation & Lifting Equipment Regulations 1998 (LOLER).

Lifting Pin Characteristics

Anchor Type: **T025-055**
 Anchor Length : **55mm**
 dia : **14mm**
 Foot dia : **35mm**
 Load Class : **2.5 tonnes**

IMPORTANT NOTE :

Prior to lifting older / pre-used lids, check the lifting pins for wear / corrosion and check the lid for cracks. If the lid is cracked or the pins are worn / damaged, it could fail when lifting.

2. Concrete

- Characteristic 28 day cube strength = 50 N/mm² min.
- Concrete is Class A1 Fire Resistant in accordance with clause 4.3.4.4 of EN 13369

3. Manufacture

- Manufactured to : **BS EN 1433 : 2002**
- Rated for : **BS EN 124 - DN400 (Group 4) loading**

4. Physical & Chemical Properties

- Appearance : Grey in Colour
- Other Chemical Properties : Not Applicable

5. Design

- Design Life : **>100 years**

6. Manufacture Tolerances

- L/W/H **±5mm**

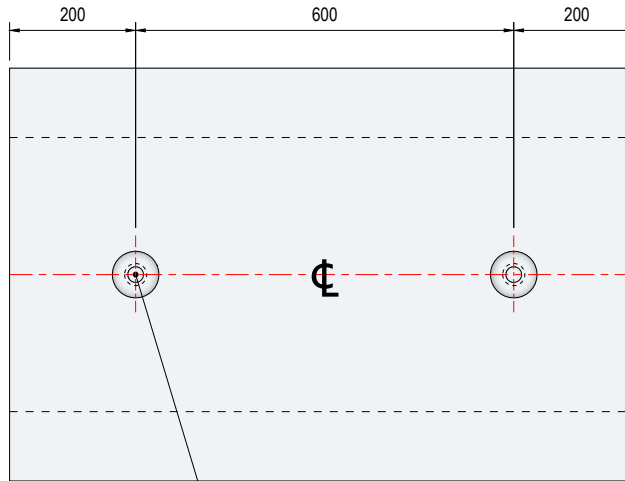

2 x 2.5t Lifting Pin x 55mm long
 (factor of safety x 3).

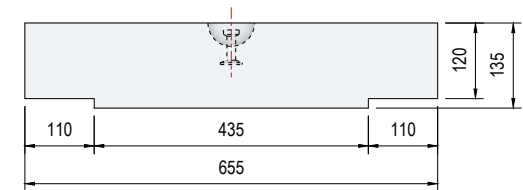
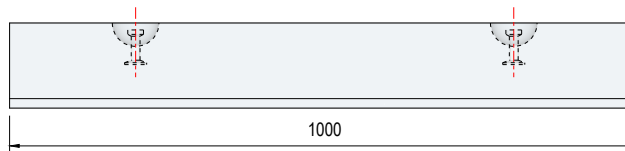
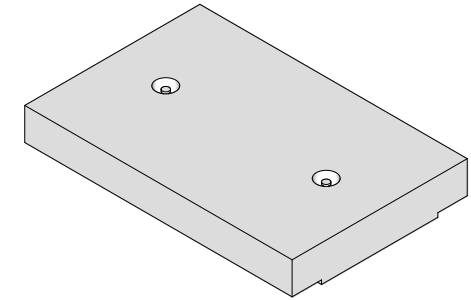

C	27.09.23	Lid lifting points changed from M16 Threaded sockets to 2.5t lifting pins.	CTC	RMD
B	24.02.21	Drawing updated to BS EN124 Class D400 Rating.	CTC	RMD
A	21.02.21	Amended to suit revised mould details.	CTC	RMD
O	21.04.16	First Information.	CTC	RMD
REV	DATE	REASON FOR ISSUE	DRN	APP

TITLE				
Channel Lid 1000mm x 655mm x 135mm				
Elite Product Code : 1197				
		DRN	CTC	CHKD RMD
		DATE	21-04-16	

ELITE PRECAST CONCRETE LTD HALESFIELD 9, TELFORD SHROPSHIRE TF7 4QW www.eliteprecast.co.uk		
SIZE A4	SCALE 1:12	
DRG EPC-1197	REV C	