

1. Handling

- Unit Weight

Unit Ref : **1075 Duct / Channel**
 Weight : **955 kg**
 (including rebar)

- Weight is based on 2,350 kg/m³
- Lifting system is by means of 4 no. 55mm long spherical pin anchors rated at 2.5 tonnes with a safety factor of 3.
- Lifting is achieved by use of 4 no. 2.5t rated suitable pin anchor ring clutches or combination ring clutches only and should comply with the Lifting Operation & Lifting Equipment Regulations 1998 (LOLER).

Lifting Pin Characteristics

Anchor Type: **T025-055**
 Anchor Length : **55mm**
 dia : **14mm**
 Foot dia : **35mm**
 Load Class : **2.5 tonnes**

IMPORTANT NOTE :

Prior to lifting older / pre-used channels, check the lifting pins for wear / corrosion and check the channel for cracks. If the channel is cracked or the pins are worn / damaged, it could fail when lifting.

2. Concrete

- Characteristic 28 day cube strength = 50 N/mm² min.
- Concrete is Class A1 Fire Resistant in accordance with clause 4.3.4.4 of EN 13369

3. Manufacture

- Manufactured to : **BS EN 13369 : 2013**

4. Physical & Chemical Properties

- Appearance : Grey in Colour
- Other Chemical Properties : Not Applicable

5. Design

- Design Life : **>100 years**

6. Manufacture Tolerances

- Length **±5mm**
- Width **±5mm**
- Height **±5mm**

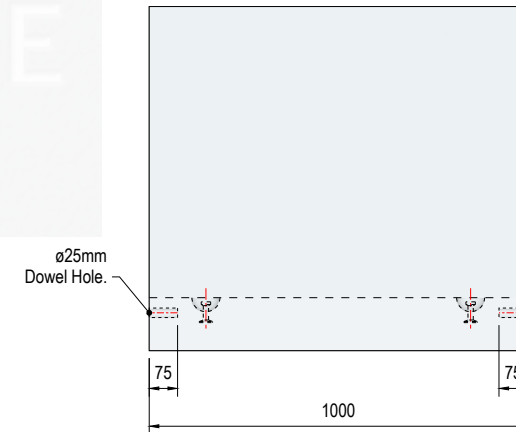
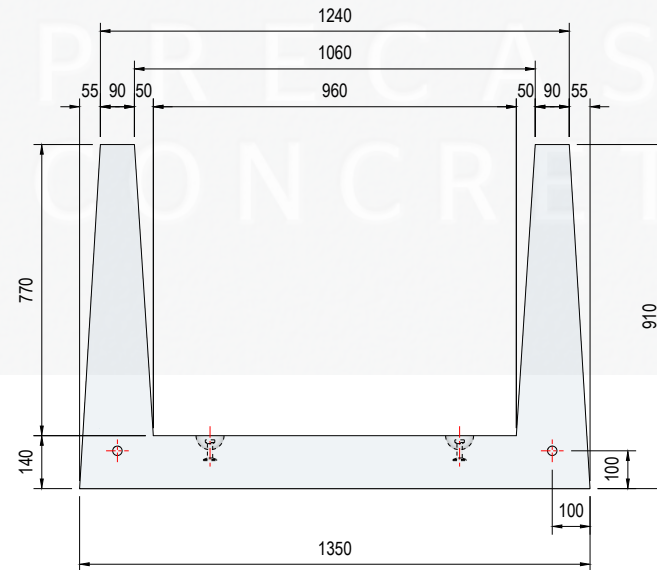
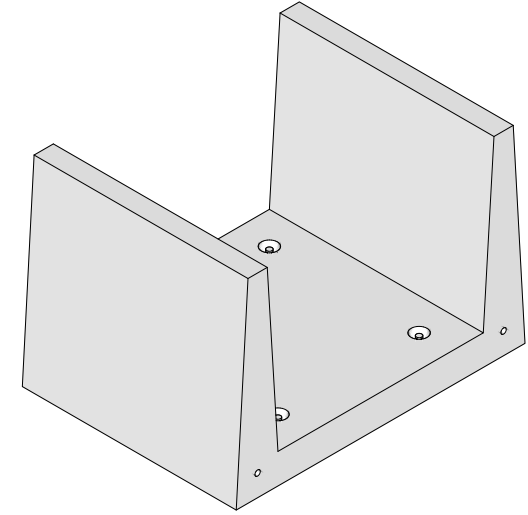
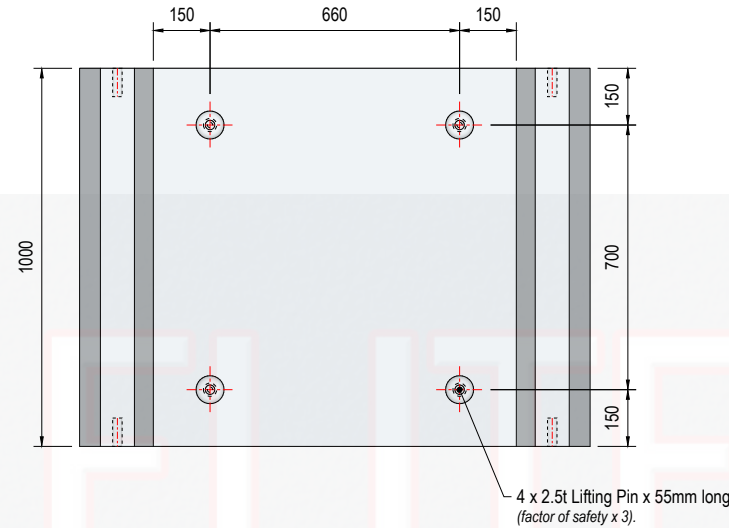

REV	DATE	REASON FOR ISSUE	DRN	APP
B	27.09.23	Channel lifting points changed from M20 Sockets to 2.5t lifting pins.	CTC	RMD
A	03.01.18	Drawing revised & updated.	CTC	RMD
O	21.04.16	First Information.	CTC	RMD

TITLE
Channel Section 960mm x 770mm (Internal)
1000mm x 1350mm x 910mm
 Elite Product Code : **1075**

DRN **CTC** CHKD **RMD** DATE **21-04-16**

ELITE PRECAST CONCRETE LTD
 HALESFIELD 9, TELFORD
 SHROPSHIRE TF7 4QW
 www.eiiteprecast.co.uk



SIZE **A4** SCALE **1:20** DRG **EPC-1075** REV **B**